

CENTRAL PNEUMATIC®

**INDUSTRIAL BLAST CABINET
WITH DUAL DOORS**

Model 94274

ASSEMBLY AND OPERATING INSTRUCTIONS

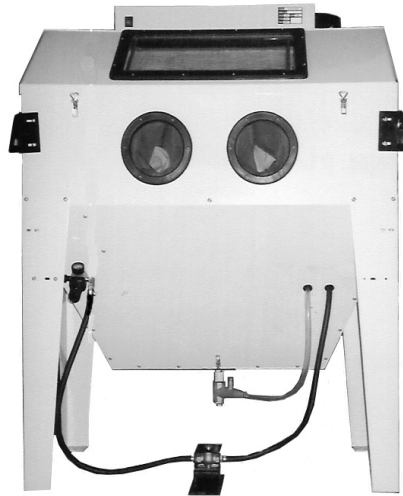

Diagrams within this manual may not be drawn proportionally.
Due to continuing improvements, actual product may differ slightly from the product described herein.

Distributed exclusively by Harbor Freight Tools®.

3491 Mission Oaks Blvd., Camarillo, CA 93011

Visit our website at: <http://www.harborfreight.com>



**Read this material before using this product.
Failure to do so can result in serious injury.
SAVE THIS MANUAL.**

Copyright© 2006 by Harbor Freight Tools®. All rights reserved. No portion of this manual or any artwork contained herein may be reproduced in any shape or form without the express written consent of Harbor Freight Tools.

For technical questions or replacement parts, please call 1-800-444-3353.

PRODUCT SPECIFICATIONS

Electrical Requirements	120 VAC / 60 Hz / 40 Watts (Cabinet) 110 VAC / 60 Hz / 12.0 AMPs (Vacuum Motor) Power Cord Type: 18 AWG x 3C SJT x 76" Long Power Plug Type: 3-Prong, Grounded Fluorescent Light Type: 18 Watt, 23" L x 1" Diameter (Qty. 2)
Working Pressure	50 ~ 125 PSI
Pressure Gauge Scale	0 ~ 150 PSI: Numbered @ 30 PSI Increments / Marked @ 5 PSI Increments 0 ~ 1 MPa: Numbered @ 0.2 MPa Increments / Marked @ 0.01 MPa Increments
Air Consumption	13 ~ 15 SCFM @ 80 PSI
Air Inlet Size	3/8"-18 NPT
Abrasive Capacity	Approximately 15 Pounds
Overall Dimensions	51" Wide x 36" Deep x 65-3/4" High (w/Dust Collector)
Inner Cabinet Dimensions	47-3/4" Wide x 24" Deep x 22-1/2" High (at Rear) 47-3/4" Wide x 24" Deep x 14" High (at Front)
Side Door Dimensions	20" Wide x 19-1/2" High (at Rear) / 20" Wide x 10" High (at Front)
Front Window Panel Dimensions	46" Wide x 13-1/2" High
Blast Gun Dimensions	6-1/2" Long x 1-3/4" Wide x 7-3/8" High
Additional Features	Foot Pedal Operated / Dual Side Doors
Accessories	6mm Ceramic Nozzle / 7mm Ceramic Nozzle
Unit Weight	250 Pounds (Empty)

SAVE THIS MANUAL

You will need this manual for the safety warnings and precautions, assembly, operating, inspection, maintenance and cleaning procedures, parts list and assembly diagram. Keep your invoice with this manual. Write the invoice number on the inside of the front cover. Keep this manual and invoice in a safe and dry place for future reference.

GENERAL SAFETY RULES AND PRECAUTIONS

 **WARNING!**
READ AND UNDERSTAND ALL INSTRUCTIONS
Failure to follow all instructions listed below may result in electric shock, fire, and/or serious injury.
SAVE THESE INSTRUCTIONS

WORK AREA

- 
Do not operate power tools in explosive atmospheres, such as in the presence of flammable liquids, gases, or dust. Power tools create sparks which may ignite the dust or fumes.

2. **Keep bystanders, children, and visitors away while operating a power tool.** Distractions can cause you to lose control. Protect others in the work area from debris such as chips and sparks. Provide barriers or shields as needed.

PERSONAL SAFETY

1. **Stay alert. Watch what you are doing, and use common sense when operating a power tool. Do not use a power tool while tired or under the influence of drugs, alcohol, or medication.** A moment of inattention while operating power tools may result in serious personal injury.
2. **Dress properly. Do not wear loose clothing or jewelry. Contain long hair. Keep your hair, clothing, and gloves away from moving parts.** Loose clothes, jewelry, or long hair can be caught in moving parts.
3. **Avoid accidental starting. Be sure the Power Switch (1A) is in its “OFF” position before performing any service, maintenance, or cleaning procedures on the unit.**
4. **Remove adjusting keys or wrenches before turning the Blast Cabinet on.** A wrench or a key that is left attached to a moving part of the machine may result in personal injury.
5. **Do not overreach. Keep proper footing and balance at all times.** Proper footing and balance enables better control of the power tool in unexpected situations.
6. **Use safety equipment.** Always wear ANSI-approved safety impact eye glasses under a full face shield and a respirator when operating the Blast Cabinet. Also, wear heavy duty work boots, long trousers, and long sleeve shirt.

TOOL USE AND CARE

1. **Do not force the tool. Use the correct tool for your application.** The correct tool will do the job better and safer at the rate for which it is designed.
2. **Do not use the Blast Cabinet if the Power Switch (1A) does not turn the tool on or off.** Any tool that cannot be controlled with its power switch is dangerous and must be replaced.
3. **Store idle tools out of reach of children and other untrained persons.** Tools are dangerous in the hands of untrained users.
4. **Maintain tools with care.** Properly maintained tools are less likely to bind and are easier to control. Do not use a damaged tool. Tag damaged tools “Do not use” until repaired.

5. **Check for misalignment or binding of moving parts, breakage of parts, and any other condition that may affect the tool's operation. If damaged, have the tool serviced before using.** Many accidents are caused by poorly maintained tools.
6. **Use only accessories that are recommended by the manufacturer for your model.** Accessories that may be suitable for one tool may become hazardous when used on another tool.

SERVICE

1. **Tool service must be performed only by qualified repair personnel.** Service or maintenance performed by unqualified personnel could result in a risk of injury.
2. **When servicing a tool, use only identical replacement parts. Follow instructions in the “*Inspection, Maintenance, And Cleaning*” section of this manual.** Use of unauthorized parts or failure to follow maintenance instructions may create a risk of electric shock or injury.

SPECIFIC SAFETY WARNINGS AND PRECAUTIONS





1.  **WARNING!** Always wear ANSI-approved safety impact eye glasses under a full face shield and a respirator when operating the Blast Cabinet. Also, wear heavy duty work boots, long trousers, and long sleeve shirt.
2. **Stay within air pressure capacity (50 ~ 125 PSI).** Never operate the Blast Cabinet above **125 PSI**.
3. **Keep children away.** Children must never be allowed in the work area. Do not let them handle equipment, tools, extension cords, or air hoses.
4. **Store idle equipment.** When not in use, the Blast Cabinet must be stored in a dry location to inhibit rust. Always lock up the machine and keep out of reach of children.
5. **Use the right tool for the job.** Do not attempt to force small equipment or attachments to do the work of a larger industrial equipment and attachments. There are certain applications for which this product was designed. It will do the job better and more safely at the rate for which it was intended. Do not modify this product, and do not use this product for a purpose for which it was not intended.
6. **Dress properly.** Do not wear loose clothing or jewelry as they can be caught in moving parts. Protective, electrically non-conductive clothes and non-skid footwear are recommended when working. Wear restrictive hair covering to contain long hair.
7. **Do not overreach.** Keep proper footing and balance at all times. Do not reach over or across running tools or air hoses.

8. **Disconnect air hose and release any built-up air pressure.** Never service the Blast Cabinet or disassemble with the air hose attached. Always release any built-up air even after disconnecting hose. Disconnect the Blast Cabinet when not in use.
9. **Stay alert.** Watch what you are doing. Use common sense. Do not operate any tool or equipment when you are tired.
10. **Check for damaged parts.** Before using any tool, any part that appears damaged should be carefully checked to determine that it will operate properly and perform its intended function. Check for alignment and binding of moving parts, any broken parts, and any other condition that may affect proper operation. Any part that is damaged should be properly repaired or replaced by a qualified technician.
11. **Replacement parts and accessories.** This product is to be repaired and serviced only by a qualified technician. When this product is serviced, only identical replacement parts should be used. Use of any other parts will void the warranty. Only use accessories intended for use with this tool. Approved accessories are available from Harbor Freight Tools.
12. **Do not operate this product if under the influence of alcohol or drugs.** Read warning labels if taking prescription medicine to determine if your judgement or reflexes are impaired while taking drugs. If there is any doubt, do not operate the tool.
13. **Maintenance.** The maintenance outlined in the “Maintenance” section should be performed regularly. For your safety, this product should be serviced or repaired regularly only by a qualified technician.
14. **Compressed air only.** Use clean, dry, regulated, compressed air at between **50 and 125 PSI**. Never use oxygen, carbon dioxide, combustible gases, or any other bottled gas as a power source for this product.
15. **Avoid working alone.** If an accident happens, an assistant can bring help.
16. **Maintain labels and nameplates on the Blast Cabinet.** These carry important information. If unreadable or missing, contact Harbor Freight Tools for a replacement.
17. **Maintain a firm grip on the Blast Gun when in use.**
18. **Never point the Blast Gun toward yourself, other people, or animals.** Keep all people and animals safely away from the work area.
19. **Industrial applications must follow OSHA requirements.**

20. **Whenever possible, perform an abrasive blasting test on a small area of the object to be blasted.** If necessary, adjust the distance to the object and/or change the Nozzle of the Blast Gun for more effective results.
21. **Make sure to read and understand all safety warnings and precautions as outlined in the manufacturer’s manual for the object you intend to blast with abrasives.**
22. **Avoid unintentional starting.** Make sure the Power Switch (1A) on the Blast Cabinet is in its “OFF” position when the tool is not being used.
23.  **WARNING! NEVER use sand as a blasting medium. Abrasive blasting with media containing crystalline silica can cause serious or fatal respiratory disease.** Exposure to crystalline silica may cause silicosis (a serious lung disease), cancer, and death. Exposure to aluminum oxide (a dust generated from material removing processes) can result in eye, skin, and breathing irritation. Always use an ANSI-approved respirator, safety impact eye glasses, and a full face shield. Avoid skin exposure. Proper ventilation in the work area is required. Read and understand the **ten** recommended measures below to reduce crystalline silica exposure in the workplace and prevent silicosis and silicosis related injuries and deaths.

The following ten measures are recommended to reduce crystalline silica exposures in the workplace and prevent silicosis and silicosis related injuries and deaths:

1. Prohibit silica sand (or other substances containing more than 1% crystalline silica) as an abrasive blasting material and substitute less hazardous materials.
2. Conduct air monitoring to measure worker exposures.
3. Use containment methods such as blast-cleaning machines and cabinets to control the hazard and protect adjacent workers from exposure.
4. Practice good personal hygiene to avoid unnecessary exposure to silica dust.
5. Wear washable or disposable protective clothes at the worksite. Shower, and change into clean clothes before leaving the worksite to prevent contamination of cars, homes, and other work areas.
6. Use respiratory protection when source controls cannot keep silica exposures below the recommended levels.
7. Provide periodic medical examinations for all workers who may be exposed to crystalline silica.
8. Post signs to warn workers about the hazard and to inform them about required protective equipment.
9. Provide workers with training that includes information about health effects, work practices, and protective equipment for crystalline silica.

10. Report all cases of silicosis to State health departments and to OSHA or the Mine Safety and Health Administration (MSHA).
24. **Before each use, check the seal on all doors of the Blast Cabinet.** Only operate the Blast Cabinet with all doors securely closed.
25.  **WARNING!** This product, when used for abrasive blasting and similar applications, produces chemicals known to the State of California to cause cancer and birth defects (or other reproductive harm). (*California Health & Safety Code 25249.5, et seq.*)
26.  **WARNING!** The warnings, cautions, and instructions discussed in this instruction manual cannot cover all possible conditions and situations that may occur. It must be understood by the operator that common sense and caution are factors which cannot be built into this product, but must be supplied by the operator.
27.  **WARNING!** People with pacemakers should consult their physician(s) before using this product. Electromagnetic fields in close proximity to to a heart pacemaker could cause interference to or failure of the pacemaker.
28.  **WARNING!** The brass components of this product contain lead, a chemical known to the state of California to cause birth defects (or other reproductive harm). (*California Health & Safety code 25249.5, et seq.*)
29. For best service, you should incorporate a regulator, and in-line filter, as shown in the diagram on the next page. Hoses, couplers, regulators, and filters are all available at Harbor Freight Tools. **(See Figure A, next page.)**

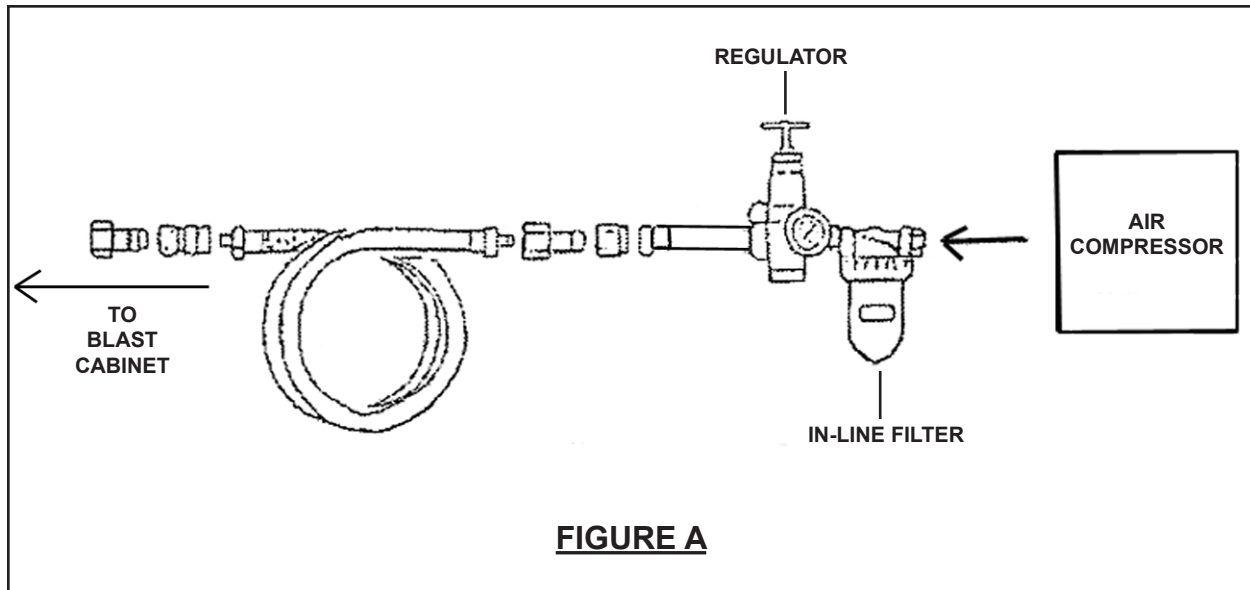

SAVE THESE INSTRUCTIONS

GROUNDING

⚠ WARNING!

Improperly connecting the grounding wire can result in the risk of electric shock. Check with a qualified electrician if you are in doubt as to whether the outlet is properly grounded. Do not modify the power cord plug provided with the tool. Never remove the grounding prong from the plug. Do not use the tool if the power cord or plug is damaged. If damaged, have it repaired by a service facility before use. If the plug will not fit the outlet, have a proper outlet installed by a qualified electrician.

GROUNDED TOOLS: TOOLS WITH THREE PRONG PLUGS

1. Tools marked with "Grounding Required" have a three wire cord and three prong grounding plug. The plug must be connected to a properly grounded outlet. If the tool should electrically malfunction or break down, grounding provides a low resistance path to carry electricity away from the user, reducing the risk of electric shock. **(See Figure B, next page.)**
2. The grounding prong in the plug is connected through the green wire inside the cord to the grounding system in the tool. The green wire in the cord must be the only wire connected to the tool's grounding system and must never be attached to an electrically "live" terminal. **(See Figure B, next page.)**

3. Your tool must be plugged into an appropriate outlet, properly installed and grounded in accordance with all codes and ordinances. The plug and outlet should look like those in the following illustration. (See Figure B.)

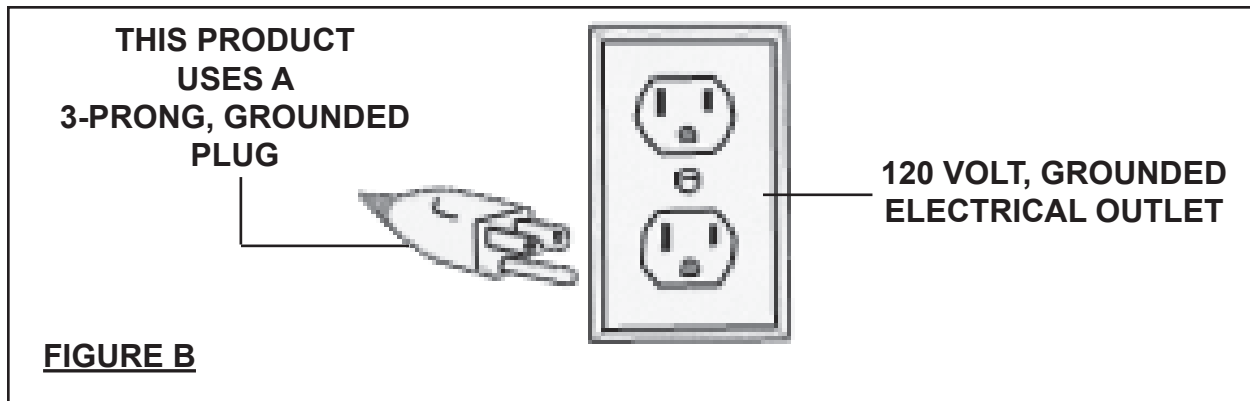

DOUBLE INSULATED TOOLS: TOOLS WITH TWO PRONG PLUGS

4. Tools marked “Double Insulated” do not require grounding. They have a special double insulation system which satisfies OSHA requirements and complies with the applicable standards of Underwriters Laboratories, Inc., the Canadian Standard Association, and the National Electrical Code. (See Figure C.)
5. Double insulated tools may be used in either of the 120 volt outlets shown in the following illustration. (See Figure C.)

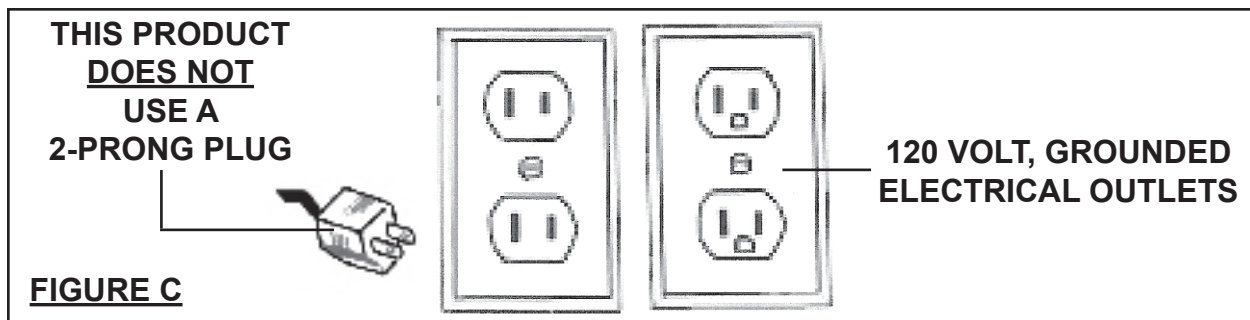

EXTENSION CORDS





1. **Grounded** tools require a three wire extension cord. **Double Insulated** tools can use either a two or three wire extension cord.
2. As the distance from the supply outlet increases, you must use a heavier gauge extension cord. Using extension cords with inadequately sized wire causes a serious drop in voltage, resulting in loss of power and possible tool damage. (See Figure D, next page.)

3. The smaller the gauge number of the wire, the greater the capacity of the cord. For example, a 14 gauge cord can carry a higher current than a 16 gauge cord. **(See Figure D.)**
4. When using more than one extension cord to make up the total length, make sure each cord contains at least the minimum wire size required. **(See Figure D.)**
5. If you are using one extension cord for more than one tool, add the nameplate amperes and use the sum to determine the required minimum cord size. **(See Figure D.)**
6. If you are using an extension cord outdoors, make sure it is marked with the suffix "W-A" ("W" in Canada) to indicate it is acceptable for outdoor use.
7. Make sure your extension cord is properly wired and in good electrical condition. Always replace a damaged extension cord or have it repaired by a qualified electrician before using it.
8. Protect your extension cords from sharp objects, excessive heat, and damp or wet areas.

RECOMMENDED MINIMUM WIRE GAUGE FOR EXTENSION CORDS* (120 VOLT)					
NAMEPLATE AMPERES (At Full Load)	EXTENSION CORD LENGTH				
	25 Feet	50 Feet	75 Feet	100 Feet	150 Feet
0 – 2.0	18	18	18	18	16
2.1 – 3.4	18	18	18	16	14
3.5 – 5.0	18	18	16	14	12
5.1 – 7.0	18	16	14	12	12
7.1 – 12.0	18	14	12	10	-
12.1 – 16.0	14	12	10	-	-
16.1 – 20.0	12	10	-	-	-

* Based on limiting the line voltage drop to five volts at 150% of the rated amperes.

SYMBOLOLOGY

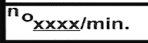
FIGURE E		Double Insulated
		Canadian Standards Association
		Underwriters Laboratories, Inc.
		Volts Alternating Current
		Amperes
		No Load Revolutions per Minute (RPM)

UNPACKING

When unpacking, check to make sure that all the parts and accessories **listed on pages 21 and 22** are included, and the product is intact and undamaged. If any parts are missing or broken, please call Harbor Freight Tools at the number shown on the cover of this manual as soon as possible.

ASSEMBLY INSTRUCTIONS

NOTE: For Additional information regarding the parts mentioned in the following pages, refer to the **Assembly Diagrams on pages 21 and 22.**

⚠ CAUTION! The Blast Cabinet weighs approximately **250 pounds**, and will require additional assistance and/or a proper lifting device during the assembly procedures.

1. Remove all parts from within the Cabinet (22). Then, with assistance, carefully place the Cabinet upside down on the floor surface. **(See Figure F.)**
2. Attach the four Cabinet Legs (23) to the Cabinet (22), using five Bolts (42) per Cabinet Leg. **NOTE:** The front left Cabinet Leg should have a *name plate* on it. Each of the two rear Cabinet Legs will also require two Self-Tapping Screws (43). **(See Figure F.)**
3. Once the Cabinet Legs (23) are attached to the Cabinet (22), stand the Cabinet upright on its Cabinet Legs. **(See Figure F.)**

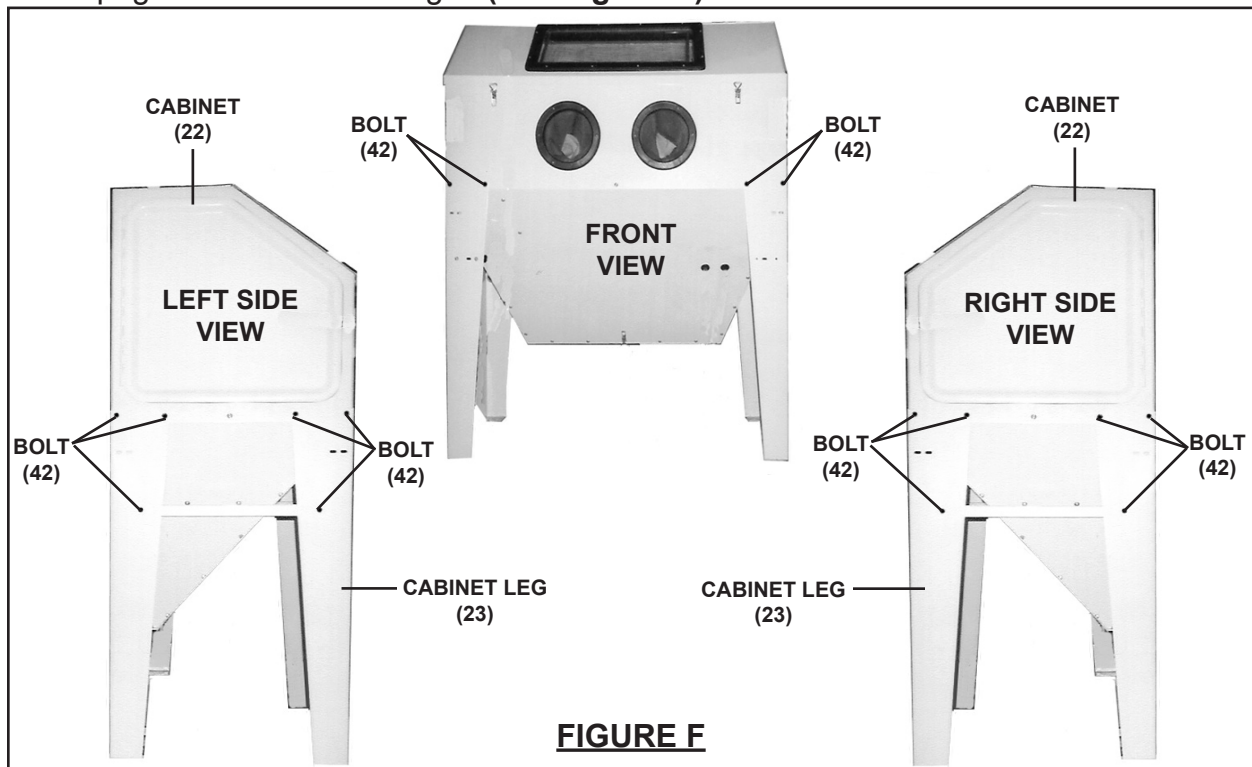
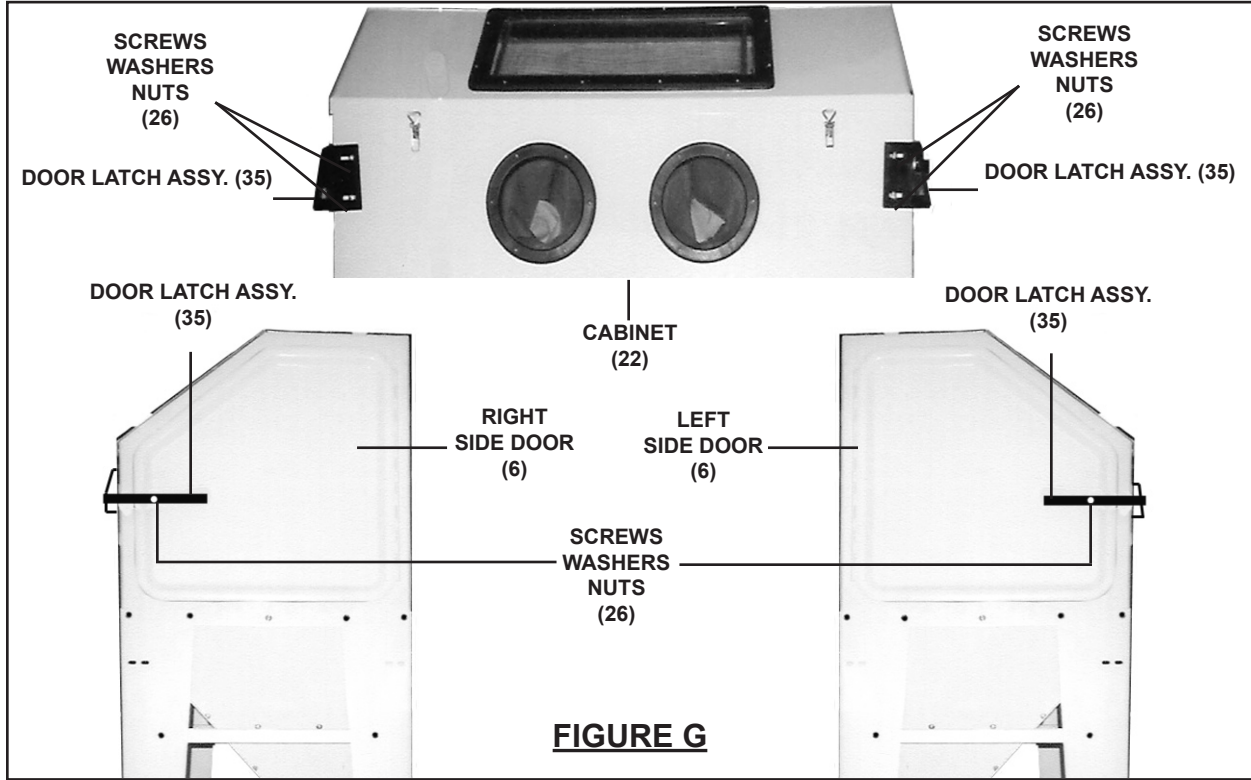
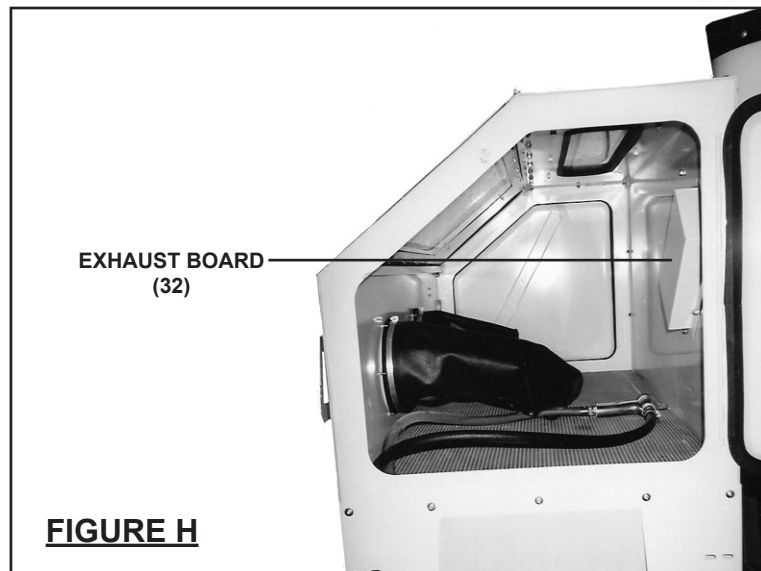

FIGURE F

4. Attach one Door Latch Assembly (35) to the left and right Side Doors (6) and the Cabinet (22), using the Screws, Washers, and Nuts (26) provided. **NOTE:** The Door Latch Assemblies may be adjusted to allow the Side Doors to shut firmly in place. (See Figure G.)



5. Remove the Exhaust Board (32) that covers the exhaust port within the Cabinet (22) and place a bead of caulking (not included) around the port to seal it. Then, replace the Exhaust Board. (See Figure H.)



- Attach the Metering Valve (13) to the rear/bottom section of the Cabinet (22), using three Self-Tapping Screws (43). **IMPORTANT:** Make sure to wrap the male threads of the Metering Valve Plug (12) with about 3" of Pipe Thread Seal Tape (41). Then, screw the Metering Valve Plug into the Metering Valve. (See Figure I.)

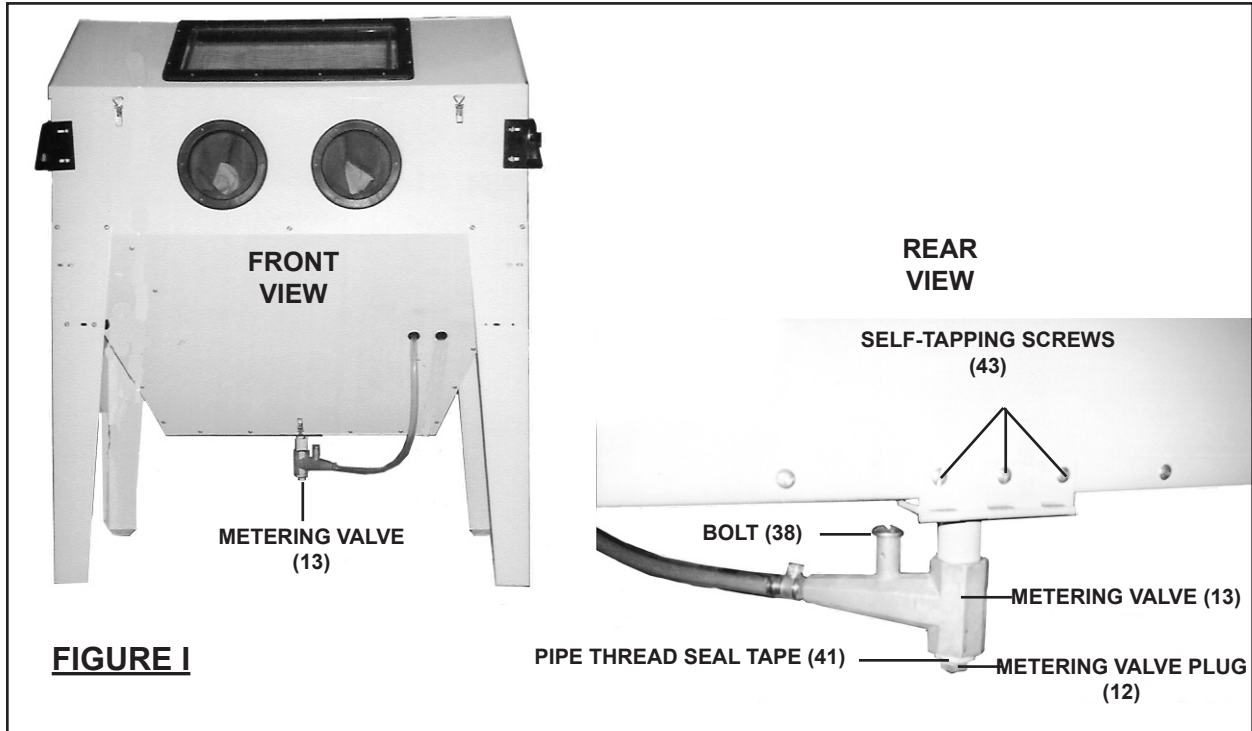

- Attach the Pressure Gauge (8) and Air Regulator (9) to the left/front Cabinet Leg (23), using the Screws, Washers, and Nuts (26) provided. (See Figure J.)

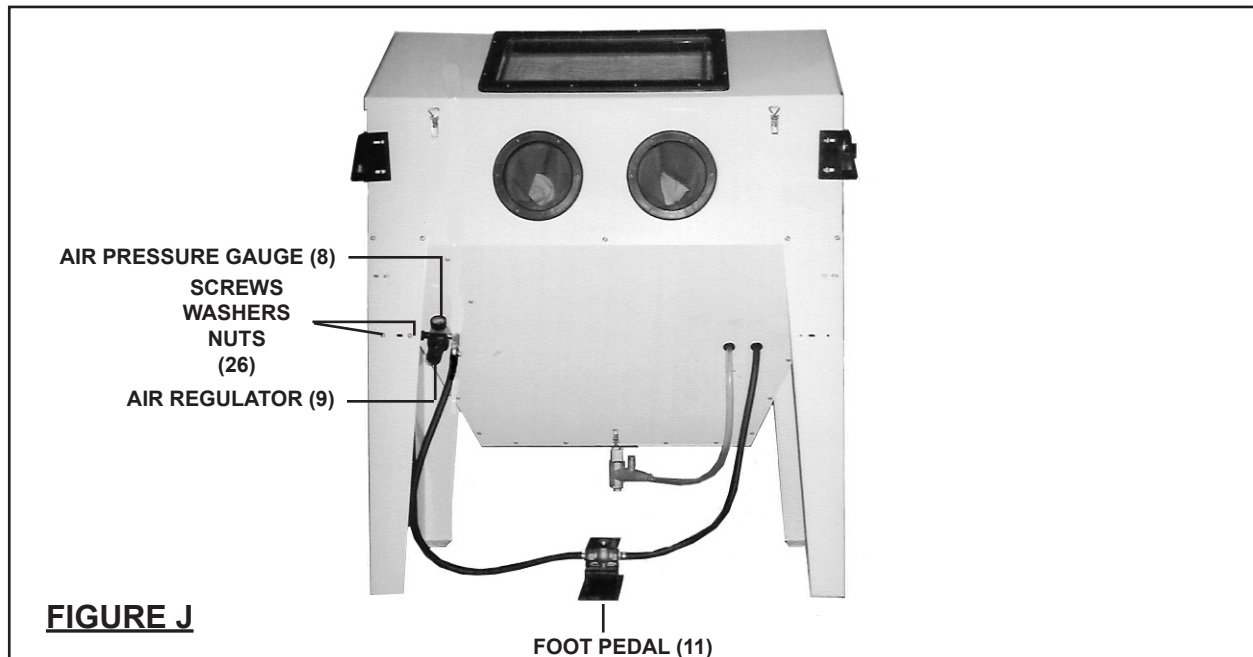

8. Attach the Lamp Housing (1) to the top of the Cabinet (22), using the Screws, Washers, and Nuts (26) provided. **NOTE:** The two Fluorescent Lamps (3) have previously been installed in the Lamp Housing by the manufacturer.



9. The Grate (39) has one small edge covered by a Rubber Strip (40). Place the Grate inside the Cabinet (22) with the Rubber Strip edge to the right/front of the Cabinet. (See Figure L.)

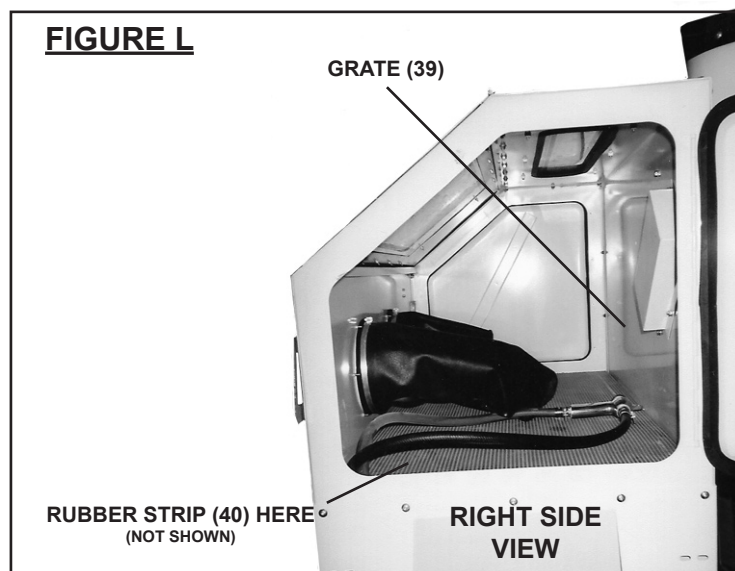



10. Prior to use, the Blast Cabinet requires the attachment of a *Female Quick Coupler* (not included) to its Air Regulator (9). To do so, wrap approximately 3" of Pipe Thread Seal Tape (41) around the male threads of the Air Regulator. Then, firmly tighten the Quick Coupler onto the Air Regulator. (See Figure J.)

OPERATING INSTRUCTIONS

Abrasive Selection:

1. The type of *media* chosen will greatly influence the amount of time needed to clean a particular surface area.
2. Abrasive blasting media include silicon carbide, glass bead, walnut shell, brass bead, and alumina.
3. If you decide to reuse media, remember, it does wear out. The sharp edges become rounder and are less effective. At that point you should replace the tank of media you are using.

To Load Media And Parts Into The Blast Cabinet:

1.  **WARNING!** Always wear ANSI-approved safety impact eye glasses under a full face shield, a respirator, and heavy duty work gloves when operating the Blast Cabinet. Also, wear heavy duty work boots, long trousers, and long sleeve shirt.
2.  **WARNING!** Never service the Blast Cabinet or disassemble with the air hose attached. Always release any built-up air even after disconnecting the hose.
3. Make sure the media used is dry to avoid clogging the Metering Valve (13) or Blast Gun (4B). Then open a Side Door (6) and pour the media (up to 15 pounds) over the Grate (39) within the Cabinet (22). **(See Figures G and L.)**
4. All parts to be blasted must be free of oil, grease, and moisture. Once cleaned and dried, place the parts on the Grate (39) within the Cabinet (22). Make sure to close and securely lock the Door Latch Assembly (35). **(See Figures G and L.)**

Nozzle Size:

1. Depending on the size (diameter) of the media, install the proper size Nozzle (6mm, 7mm) into the Blast Gun (4B). To do so, unscrew and remove the Nozzle Holding Nut (1B). Insert the desired Nozzle into the front portion of the Blast Gun. Then screw the Nozzle Holding Nut back onto the Blast Gun to secure the Nozzle in place. **(See Assy. Diagram, page 22.)**
2. **NOTE:** By changing to the next larger size of Nozzle, production can increase significantly. Larger size Nozzles produce a larger cleaning pattern. This, however, requires a higher air pressure.

Electrical Power:

1. Plug the male Power Cord from the Lamp Housing (1) into the nearest 120 volt, grounded, electrical outlet. **(See Figure K.)**
2. Turn the Power Switch (1A) on the Lamp Housing (1) to its “ON” position. The two Fluorescent Lamps (3) will illuminate. **(See Figure K.)**

Air Pressure:

1. Turn on the air compressor to supply compressed air to the Blast Cabinet.
2. The operating air pressure for the Blast Cabinet is between **50 and 125 PSI**. Pressures up to 125 PSI can be used, but this breaks down some type of media prematurely (i.e., glass bead).
3. Start by setting the Air Regulator (9) at 80 PSI. Most parts for blasting can be successfully blasted at 80 PSI. For light gauge steel, aluminum, and other more delicate parts start at a lower pressure and gradually increase the pressure until the desired finish is achieved. **NOTE:** For more pressure, turn the Air Regulator Knob *clockwise*. For less pressure, turn the Air Regulator Knob *counterclockwise*. **(See Figure J.)**

Blast Gun Angle And Distance:

1. Aim the Blast Gun (4B) at the parts at a 45 to 60 degree angle which will direct the ricochet of media towards the back of the Cabinet (22). Hold the Blast Gun approximately 6 inches from the parts being blasted. **(See Figure M.)**
2. Do not hold the Blast Gun at a 90 degree angle to the parts being blasted. This will cause the media blast to bounce back into the blast stream and slow the blasting action. Also, a 90 degree angle will cause excessive wear on the Blast Gun and viewing Glass Window (17). **(See Figure M.)**

3. **⚠ WARNING!** The Blast Gun (4B) must always be pointed away from yourself and others and only towards the parts being blasted. Never blast with any of the Side Doors (6) open. While loading and unloading media, no one, except the operator, should be near the Blast Cabinet.

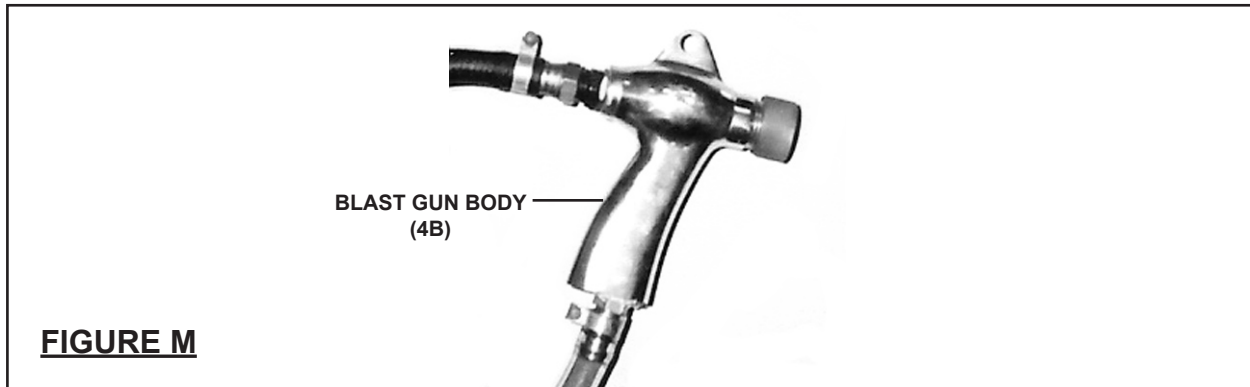

The Metering Valve:

1. The Metering Valve (13) adjusts the amount of media being pulled into the Blast Gun (4B). This Valve, located at the bottom of the hopper, has the media stored on top of it. When air is sent to the Blast Gun from the Foot Pedal (11), a vacuum is created that sucks air and media up into the Blast Gun through the clear media hose. **(See Figure I.)**
2. A Bolt (38) on the top of the Metering Valve (13) can be adjusted to vary the amount of air that is sucked through the holes in the Valve. If the holes are too far closed, the mixture will have too much media and the Blast Gun (4B) will pulsate. If the holes are too far opened, too little media will go to the Blast Gun and production will decrease. **(See Figure I.)**

Shut Down Procedures:

1. When the abrasive blasting job is completed, release pressure on the Foot Pedal (11) of the Blast Cabinet. Turn the Power Switch (1A) to its **"OFF"** position and unplug the Power Cord from its electrical outlet. Turn off the air compressor. Press the Foot Pedal again to release any remaining compressed air in the system. **(See Figure J.)**
2. Disconnect the compressor air hose from the Quick Connector on the Air Regulator (9). **(See Figure J.)**
3. If necessary, empty the Cabinet (22) of any remaining media by unscrewing and removing the Metering Valve Plug (12). Always use Pipe Thread Seal Tape (41) when replacing the Metering Valve Plug. **(See Figure I.)**



Maintaining Suction Efficiency:

1. The most common problem operators have when using a suction (venturi) Blast Cabinet is a decrease in production rates. When production rates fall the operator can usually locate the problem by checking the following:
2. **Air supply.** If the Pressure Gauge (8) on the Air Regulator (9) shows an adequate no-load supply (when the Blast Gun (4B) is not running), press the Foot Pedal (11). If the pressure drops more than a few PSI the air supply is restricted or inadequate. Clean filters and moisture separators all the way back to the air compressor. Straighten any kinked hoses. Use a master gauge (not included) to check the air pressure, or replace the existing Pressure Gauge if you suspect it is giving you false readings.
3. **Blast Gun.** The Nozzle (2D, 2E) will wear out eventually. Replace the Nozzle if its opening measures 1/16" over its original size or if it shows uneven wear. Adjust as needed for different media and conditions. A properly working Blast Gun (4B) will pull 15 to 17 inches of mercury on a manometer. **(See Assy. Diagram.)**
4. **Media.** Use quality blast media sized to the job. Damp or dirty media can bring blasting to an instant halt. Store media in a dry area and load the appropriate quantity (up to 15 pounds). Add enough media through the Grate (39) within the Cabinet (22) to have 6 inches deep of media on top of the Metering Valve (13). If you run out of media as you are blasting, add enough so it keeps circulating to the Blast Gun (4B). The media will eventually break down or get too contaminated to use. The less there is in the system, the less you will have to replace.
5. **Media delivery.** Replace any media hose that has soft spots or visible wear. Adjust the Metering Valve (13) to provide adequate flow. A mixture that is too rich will cause pulsating at the Blast Gun (4B). An unusually loud noise while blasting means the mixture is too lean. A rich mixture can result in lower impact velocities, while a lean mixture reduces the number of impacts.

TROUBLESHOOTING

1. **Blast Gun.** After 10 to 12 hours of blasting time, the Nozzle (2D, 2E) should be checked. If it shows uneven wear it should be turned 1/4 turn every 10 hours of use. Replace as needed.
2. **Caking of media.** Media caking is caused by moisture in the air supply or from oily or greasy parts. If this is not corrected the media will not flow evenly and will plug up in the Metering Valve (13) and Blast Gun (4B). Check the air supply. If water is present, install a quality moisture trap. If oily or greasy parts are being blasted, degrease and dry the part first.
3. **Reverse pressure.** If the media stops flowing occasionally, use an object to plug the Nozzle (2D, 2E) and press the Foot Pedal (11) down for about two seconds. This will cause the system to back blast through the Blast Gun (4B) and up the media hose. This will help loosen any clogs.
4. **Blast Gun air pressure drop.** Turn the Air Regulator Knob (9) and set the air pressure to 80 PSI as indicated on the Pressure Gauge (8). Push the Foot Pedal (11) while holding the Blast Gun (4B), and observe if the gauge pressure drops significantly. If the pressure drops, this indicates there is a restriction in the air supply line. This could indicate the air supply hose is too small, a reducer or quick coupler, or other piping that doesn't allow enough air through. Also, if the air compressor is too far away from the Blast Cabinet a pressure drop will result. The air supply line should be 1/2" diameter or larger.
5. **Poor visibility (excessive dust).** Check to make sure the Quick Coupler on the Air Regulator (9) is allowing air to the Cabinet (22).
6. **Poor visibility (viewing window).** The Glass Window (17) is equipped with a clear plastic protector on it and may become pitted. If necessary, replace the plastic protector and/or Glass Window.
7. **Poor media flow.** Check for moisture as discussed in Step #2 of this section. Holes in media hose will cause poor media delivery. If necessary, replace hose. Debris in media. Replace or screen media.

INSPECTION, MAINTENANCE, AND CLEANING

1.  **WARNING!** Prior to performing any inspection, maintenance, or cleaning of the Blast Cabinet, turn the Power Switch (1A) to its “OFF” position and unplug the unit from its electrical outlet. Turn off the air compressor. Press the Foot Pedal (11) of the Blast Cabinet to release any remaining compressed air in the system. Then, disconnect the compressor’s air hose from the Blast Cabinet.
2. **Before each use**, inspect the general condition of the Blast Cabinet and its accessories. Check for loose screws, misalignment or binding of moving parts, cracked or broken parts, damaged hoses, and any other condition that may affect safe operation. If abnormal noise or vibration occurs, have the problem corrected before further use. **Do not use damaged equipment.**
3. **Before, during, and after use:** Periodically, check the Water Filter in the air compressor system for excessive water build-up. If necessary, discontinue working and drain the Water Filter.
4. **To clean the exterior of the Blast Cabinet**, wipe with a clean, damp cloth using a mild detergent or mild solvent.
5. **Disposal of media:** Always follow local solid waste authority guidelines when disposing of used media.
6.  **CAUTION!** All maintenance, service, and repairs not mentioned in this manual must only be performed by a qualified service technician.

PLEASE READ THE FOLLOWING CAREFULLY

THE MANUFACTURER AND/OR DISTRIBUTOR HAS PROVIDED THE PARTS LIST AND ASSEMBLY DIAGRAM IN THIS MANUAL AS A REFERENCE TOOL ONLY. NEITHER THE MANUFACTURER OR DISTRIBUTOR MAKES ANY REPRESENTATION OR WARRANTY OF ANY KIND TO THE BUYER THAT HE OR SHE IS QUALIFIED TO REPLACE ANY PARTS OF THE PRODUCT. IN FACT, THE MANUFACTURER AND/OR DISTRIBUTOR EXPRESSLY STATES THAT ALL REPAIRS AND PARTS REPLACEMENTS SHOULD BE UNDERTAKEN BY CERTIFIED AND LICENSED TECHNICIANS, AND NOT BY THE BUYER. THE BUYER ASSUMES ALL RISKS AND LIABILITY ARISING OUT OF HIS OR HER REPAIRS TO THE ORIGINAL PRODUCT OR REPLACEMENT PARTS THERETO, OR ARISING OUT OF HIS OR HER INSTALLATION OF REPLACEMENT PARTS THERETO.

PARTS LIST

Part#	Description	Part#	Description
1	Lamp housing	21	Cabinet Lid
1A	Power switch	22	Cabinet
2	Lamp fixture	23	Cabinet Leg
3	Fluorescent Lamp (18 Watt)	24	Sealing Collodion
4	Lamp window	25	Side Door Retaining Block
5	Trim-lock window seal, PE	26	Screw, Washer, Nut
6	Side door	27	3/8" Brass Coupler
7	Adjustable Latch	28	1/2" Bend Tubular Connector
8	Pressure gauge (1/4", 150psi)	29	3/8" Bend Tubular Connector
9	Air Regulator (3/8")	30	Air Regular Base
10	Push-On Air Hose (1/2")	31	Sealing Tape
11	Foot Pedal (3/8")	32	Exhaust Board
12	Metering Valve Plug	35	Door Latch Assemblies
13	Metering Valve	36	Hole
14	Gloves Clamp	37	Cover
15	Gloves	38	Bolt
16	Window Frame cover	39	Grate
17	Glass	40	Rubber Strip
18	Protection Film, PE	41	Pipe Thread Seal Tape
19	Plastic Board	42	Bolts
20	Gloves Mounting Ring	43	Self-Tapping Screw
		44	Flat Washer
		45	Spring Washer
		46	Hex Nut M8
		47	M5x12 Bolt
		48	Hose Connector
		51	M8x20 Hex Bolts

ASSEMBLY DIAGRAM

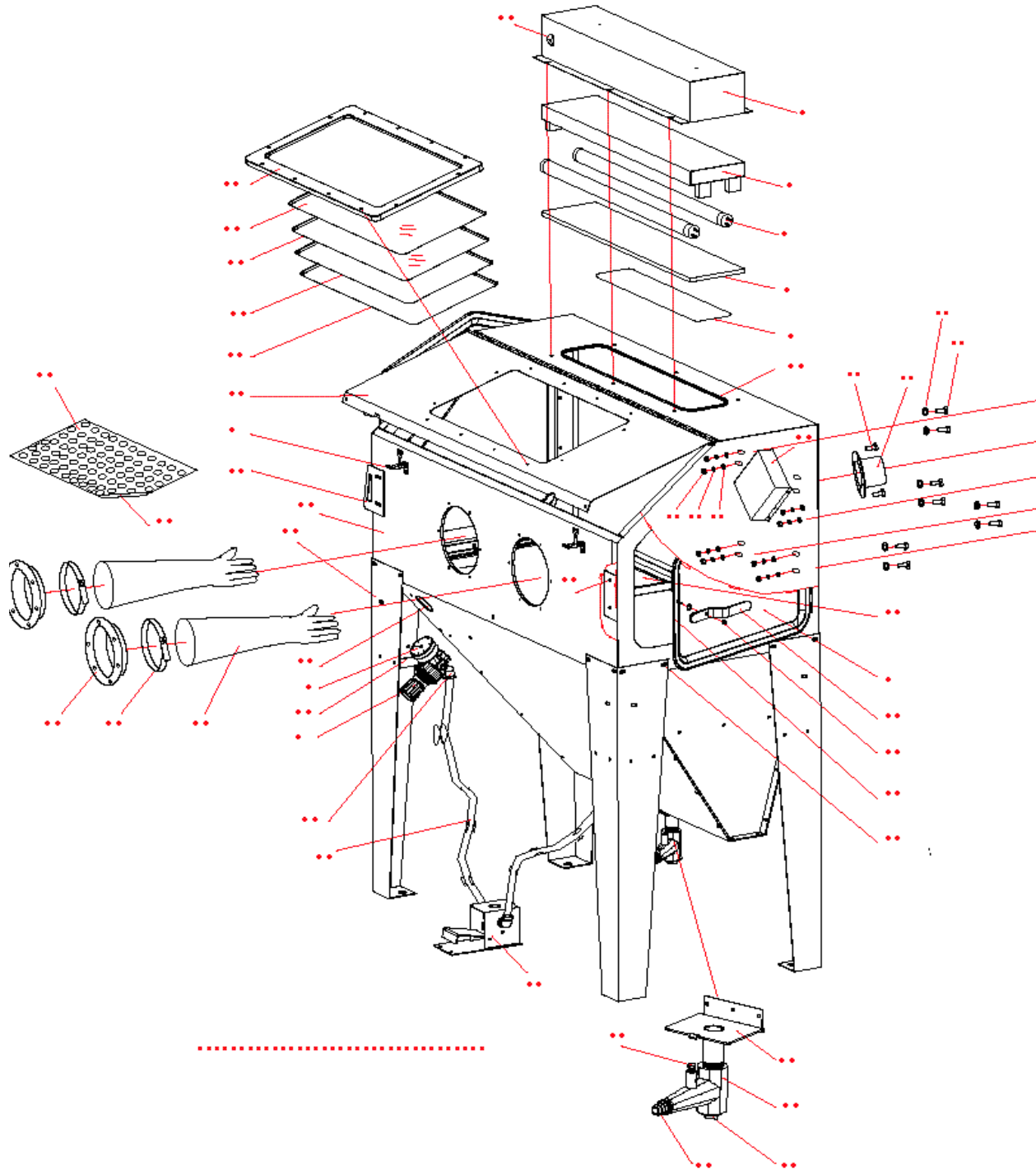

PARTS LIST & ASSEMBLY DIAGRAM - BLAST GUN

Part	Description
1B	Nozzle Holding Nut (Brass)
2D	Ceramic Nozzle (6mm)
2E	Ceramic Nozzle (7mm)
3B	Nozzle O-Ring
4B	Gun Body (Mod-U-Blast)
5B	Air Jet Hex Nut (Brass)
6B	Air Jet Sleeve
7B	Air Jet

Part	Description
8B	Swivel Air Inlet Fitting (3/8")
9B	Media Inlet Fitting (Barb 3/8")
10B	Media Hose (1/2")
11B	Air Hose (1/2")
12B	Seal
13B	Ring

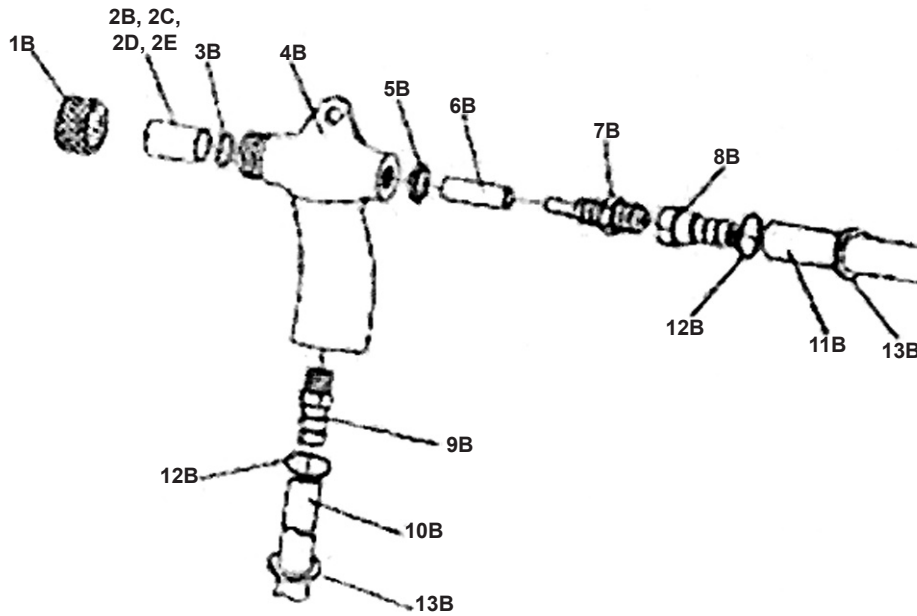

NOTE:

Some parts are listed and shown for illustration purposes only, and are not available individually as replacement parts.

ELECTRICAL SCHEMATIC

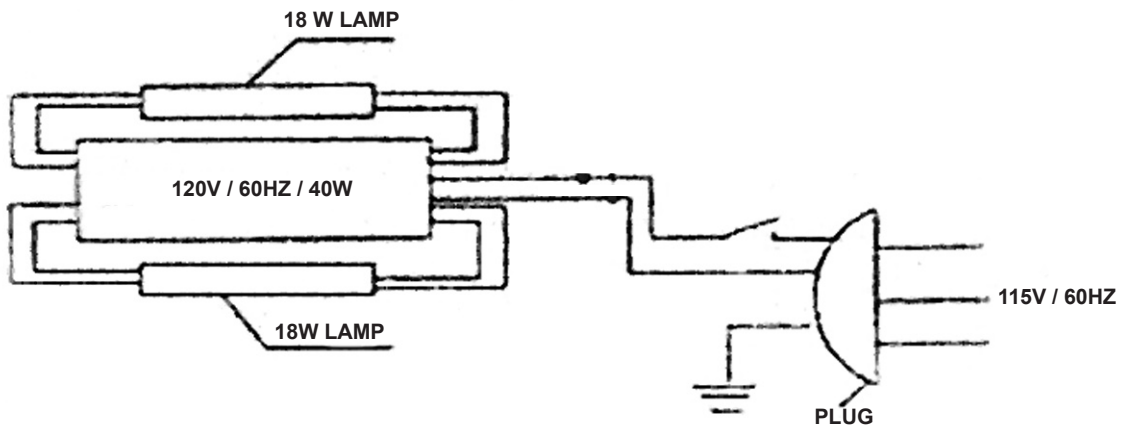

LIMITED 90 DAY WARRANTY

Harbor Freight Tools Co. makes every effort to assure that its products meet high quality and durability standards, and warrants to the original purchaser that this product is free from defects in materials and workmanship for the period of 90 days from the date of purchase. This warranty does not apply to damage due directly or indirectly, to misuse, abuse, negligence or accidents, repairs or alterations outside our facilities, criminal activity, improper installation, normal wear and tear, or to lack of maintenance. We shall in no event be liable for death, injuries to persons or property, or for incidental, contingent, special or consequential damages arising from the use of our product. Some states do not allow the exclusion or limitation of incidental or consequential damages, so the above limitation of exclusion may not apply to you. **THIS WARRANTY IS EXPRESSLY IN LIEU OF ALL OTHER WARRANTIES, EXPRESS OR IMPLIED, INCLUDING THE WARRANTIES OF MERCHANTABILITY AND FITNESS.**

To take advantage of this warranty, the product or part must be returned to us with transportation charges prepaid. Proof of purchase date and an explanation of the complaint must accompany the merchandise. If our inspection verifies the defect, we will either repair or replace the product at our election or we may elect to refund the purchase price if we cannot readily and quickly provide you with a replacement. We will return repaired products at our expense, but if we determine there is no defect, or that the defect resulted from causes not within the scope of our warranty, then you must bear the cost of returning the product.

This warranty gives you specific legal rights and you may also have other rights which vary from state to state.

3491 Mission Oaks Blvd. • PO Box 6009 • Camarillo, CA 93011 • (800) 444-3353